

MainStage 2 and Guitar to MIDI Converter

Who am I?

John Moores
Guitarist
Composer
Producer
Music Technology Consultant
Logic T3 Mentor Apple EMEA
johnmooresmusic@mac.com



Logic Studio

Music creation, audio
production, live performance



Logic Pro 9



MainStage 2



Soundtrack Pro 3



Studio Instruments



Studio Effects



Studio Sound Library



Live Performance

MainStage 2



- Perform with all the sounds from Logic Studio
- Play along with backing tracks
- Jam with live loop recording
- Create sophisticated live rigs

MainStage 2



- New Templates and browser
- Multi-mapping of controls
- Faster setup with Group Controls
- External MIDI output
- Expanded Rewire support

Playback



- Trigger backing tracks
- Independent control of each track
- Navigate using markers
- Instantly loop any section
- Sync all parts to tempo
- Change tempo on-the-fly

Loopback



- Record and loop performances
- Layer multiple parts
- Perform different instruments simultaneously
- Change sound while performing
- Create sophisticated arrangements



demo

Guitar to MIDI Converter

The Technology Guitarist

The Technology Guitarist



13



14

The Guitar



The Basic Setup

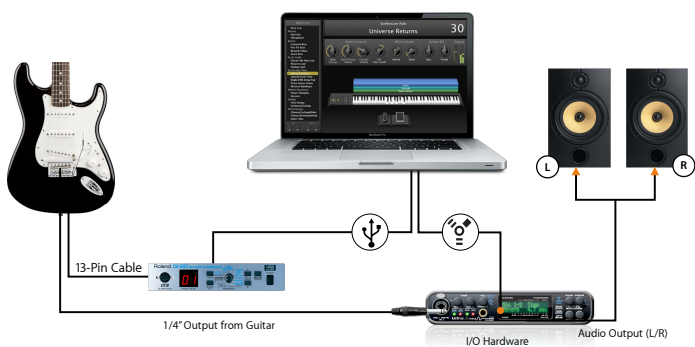

Setup and Calibration

- The guitar must be setup correctly
- The pickup must be installed correctly

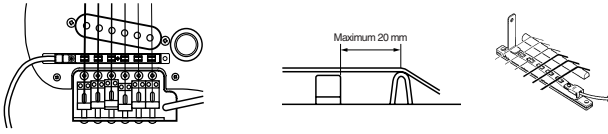

Setup and Calibration

- Calibrate the sensitivity carefully

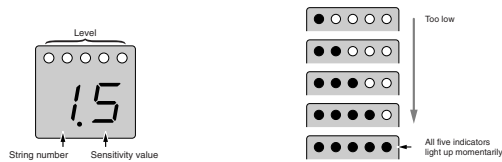

Setup and Calibration

- Choose the best dynamic response

The PLAY FEEL settings and their effects

nr: Normal

General picking, thus the standard setting.

Fl: Finger picking

Fl

The setting for when you want to perform with the feeling finger picking provides. Sensitivity is a little higher than Normal.

Hd: Hard picking

Hd

This setting is for those who pick rather hard, and the sensitivity is a little lower than Normal.

* When there is a problem with the guitar's arrangement, and the only place on GK series pickup can be installed are too close to the strings, you may be able to improve the behavior with the settings in each patch.

SF: Soft picking

SF

For picking that is a little weaker. Sensitivity is a little higher than Normal.

TP: Tapping play

TP

When making use of many kinds of picking techniques, such as tapping play (or "right-hand play"), pulling off, or hammering on. This setting provides very stable sound expression. The range of power that can be expressed is a bit narrow.

nd: No dynamics

nd

With this setting, no matter how hard or softly you play, you get uniform volume and tone. Use this setting with tones like Synth Lead or Organ when you want to transmit a feeling without expression.

Mono Mode or Poly Mode & Pitch Bend

- Mono mode transmits MIDI on 6 MIDI Channels
- Poly Mode transmits on 1 channel only
- Bend range can be set or turned off (chromatic)
- Synth patch must use the same bend range

Play to the sound!

Controller Pedals



Q&A